

Collaborative Jamming session with iphones

DMIMS 2012

Culture Lab, Newcastle

Smartphones

- Small computer :
Communication features : Wifi, bluetooth etc.
Input : touchscreen, accelerometer, mic.
- Many examples of music applications :
Programmable with pd (using rjdj or droidparty).
- Seems like the right platforms to experiment.

Global System

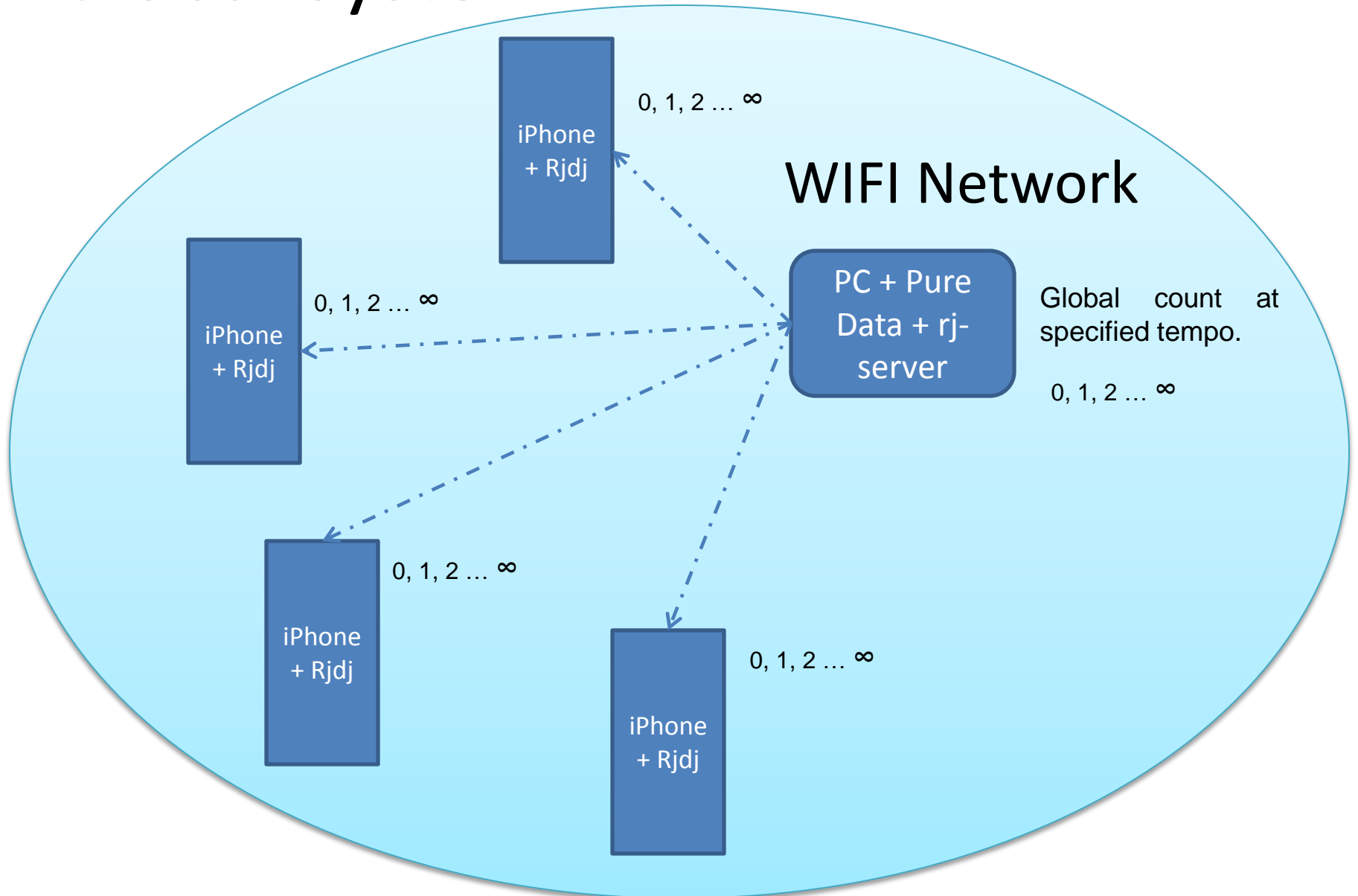

Desktop Patch

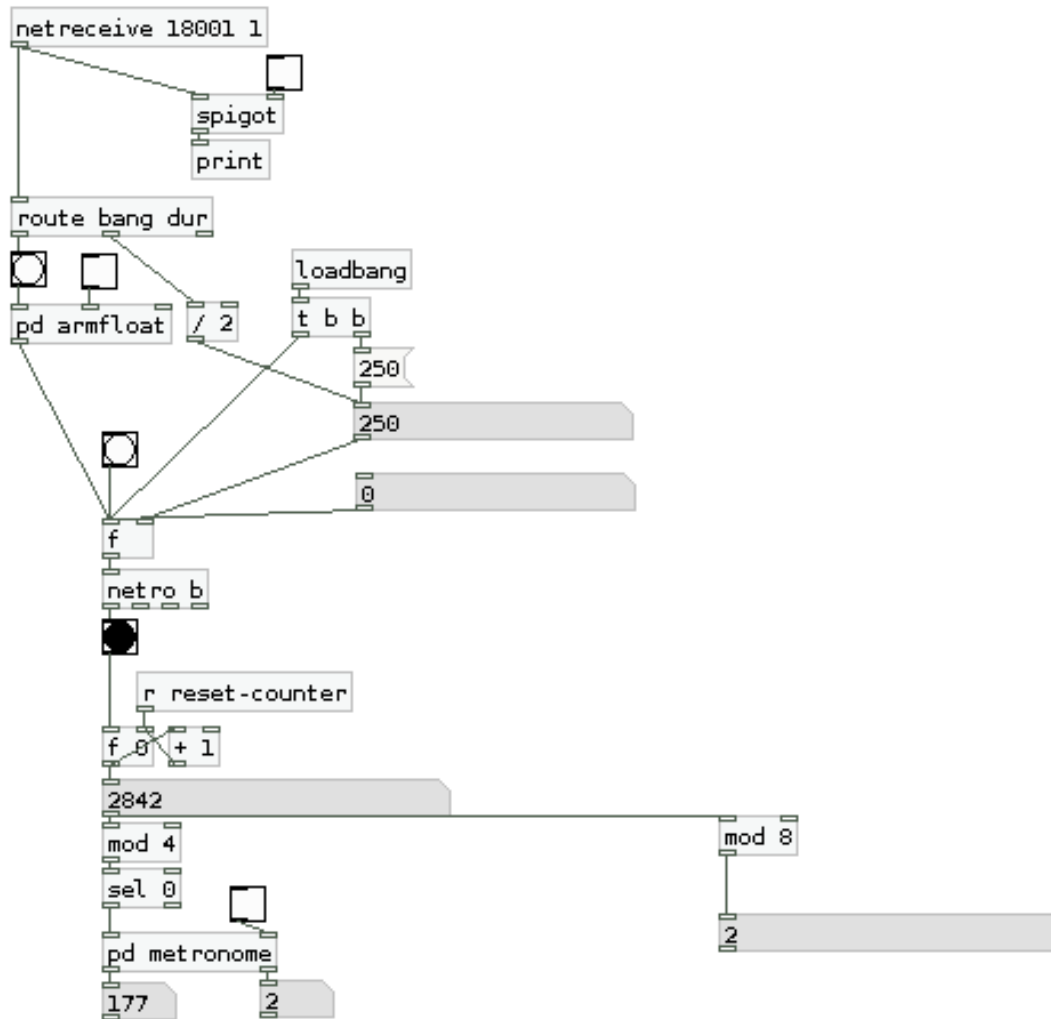

Send a beat over wifi

- Chris McCormick [netro]
 - Synchronize beat count for all the objects on the same Wifi network.
 - We get a number that we can combine with [mod] or just get a [bang].

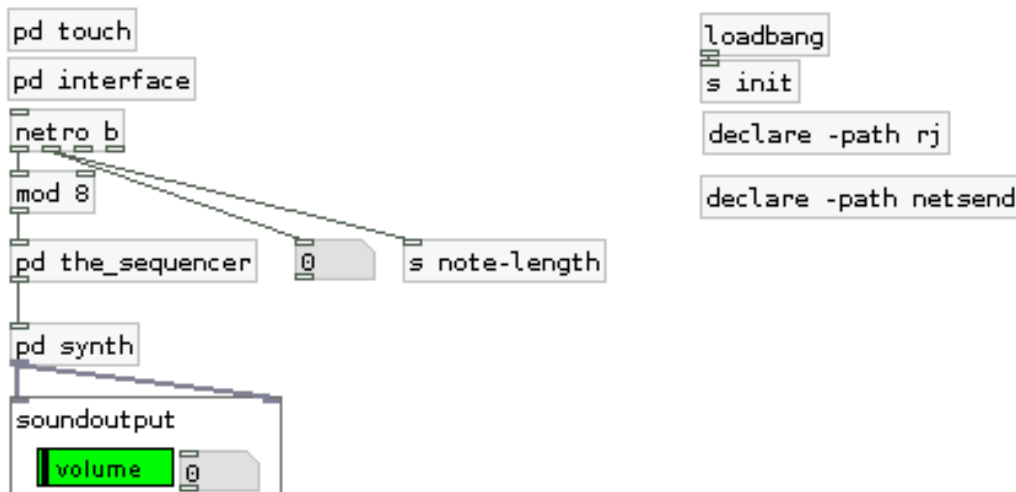

Syncing user input : [armfloat]

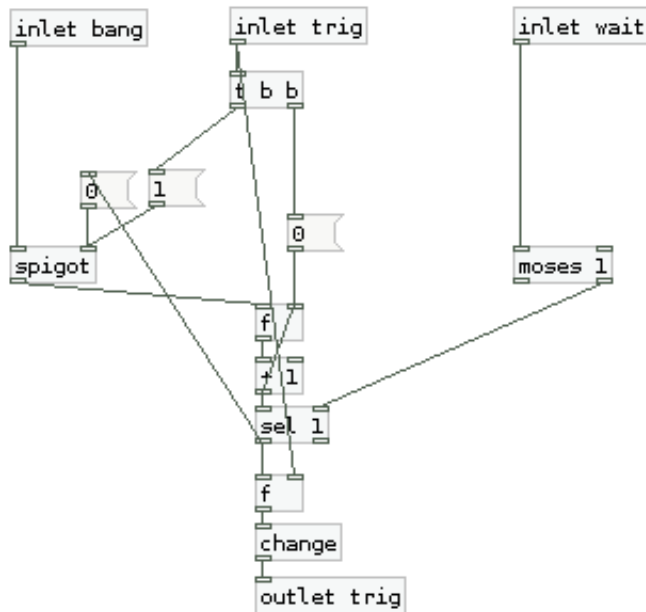

[armfloat] insides

- First inlet : get a bang from [netro].
- Second inlet : store input from user.

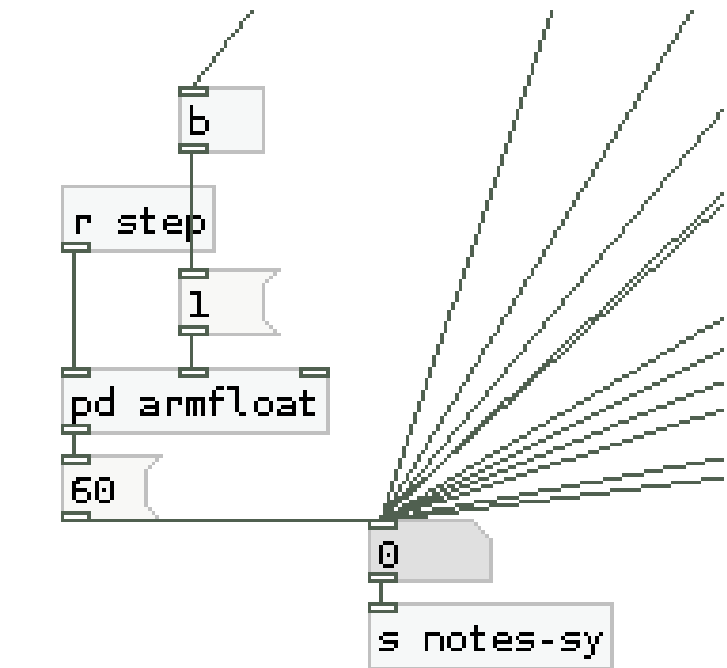

Two type of applications

- Net sequencers : netseq

- netseq1-Chip.rj
- netseq2-Chip.rj
- netseq4-Chip.rj
- netseq8-Chip.rj
- netseq8-Drums.rj
- netseq8-Ejun.rj
- netseq8-Draw.rj

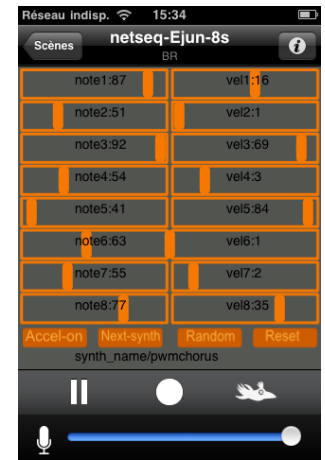
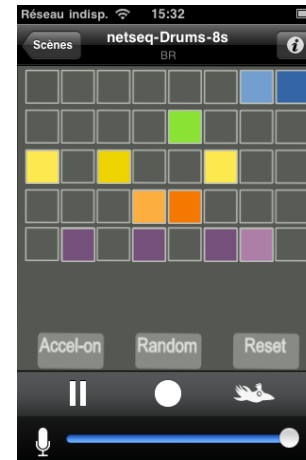

- Net performing instruments : netperf

- netperf-ShakeDrums-fullspeed.rj
- netperf-ShakeDrums-x2.rj
- netperf-TouchDrums-fullspeed.rj
- netperf-TouchSynth-div2.rj
- netperf-TouchSynth-div4.rj
- netperf-TouchSynth-div8.rj
- netperf-TouchSynth-fullspeed.rj

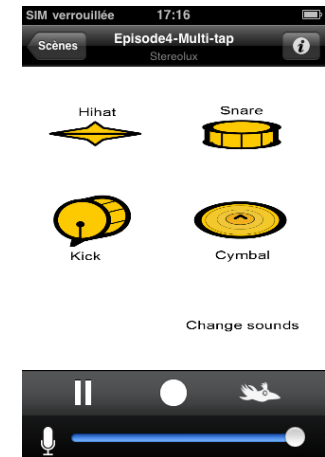
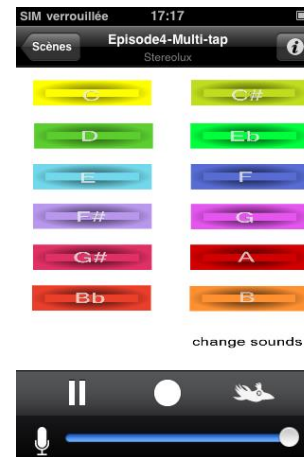

Naming of the scenes

- Netseq8-Chip

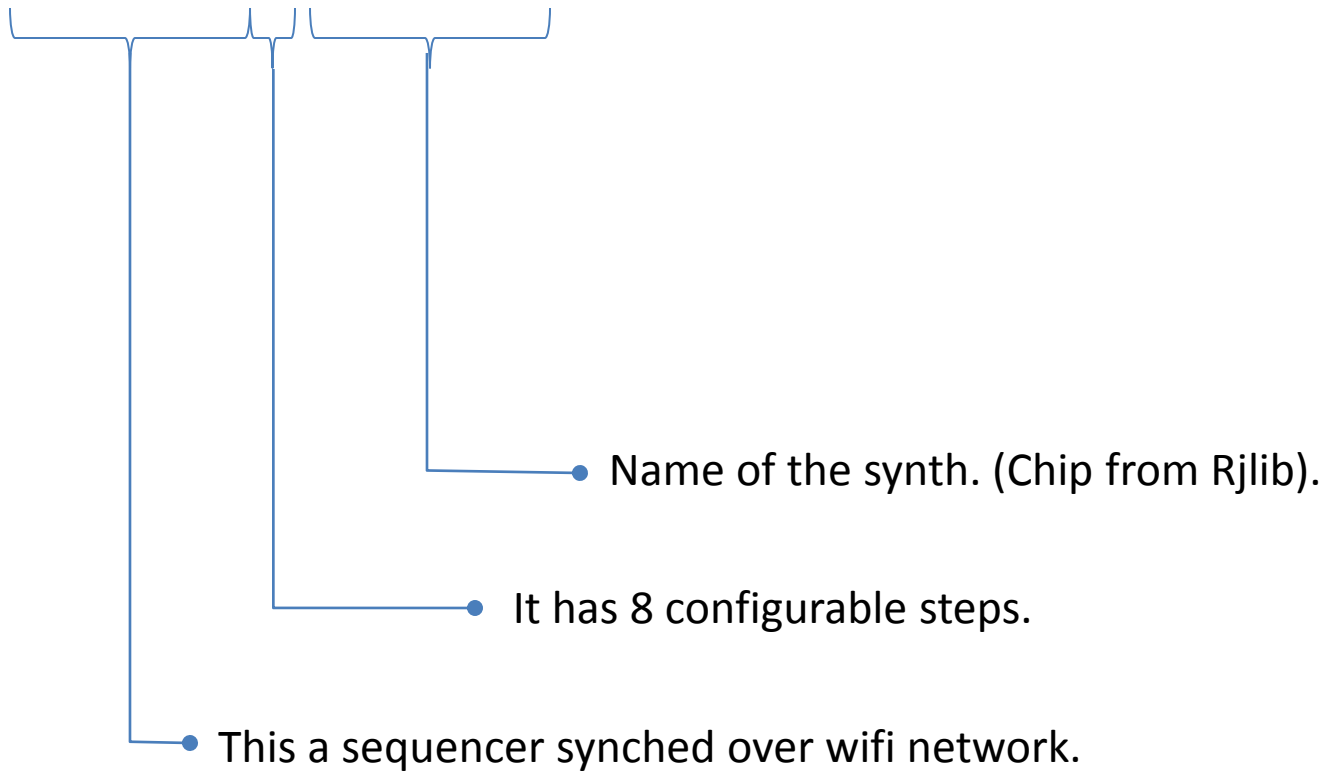

Naming of the scenes

- netperf-ShakeDrums-x2

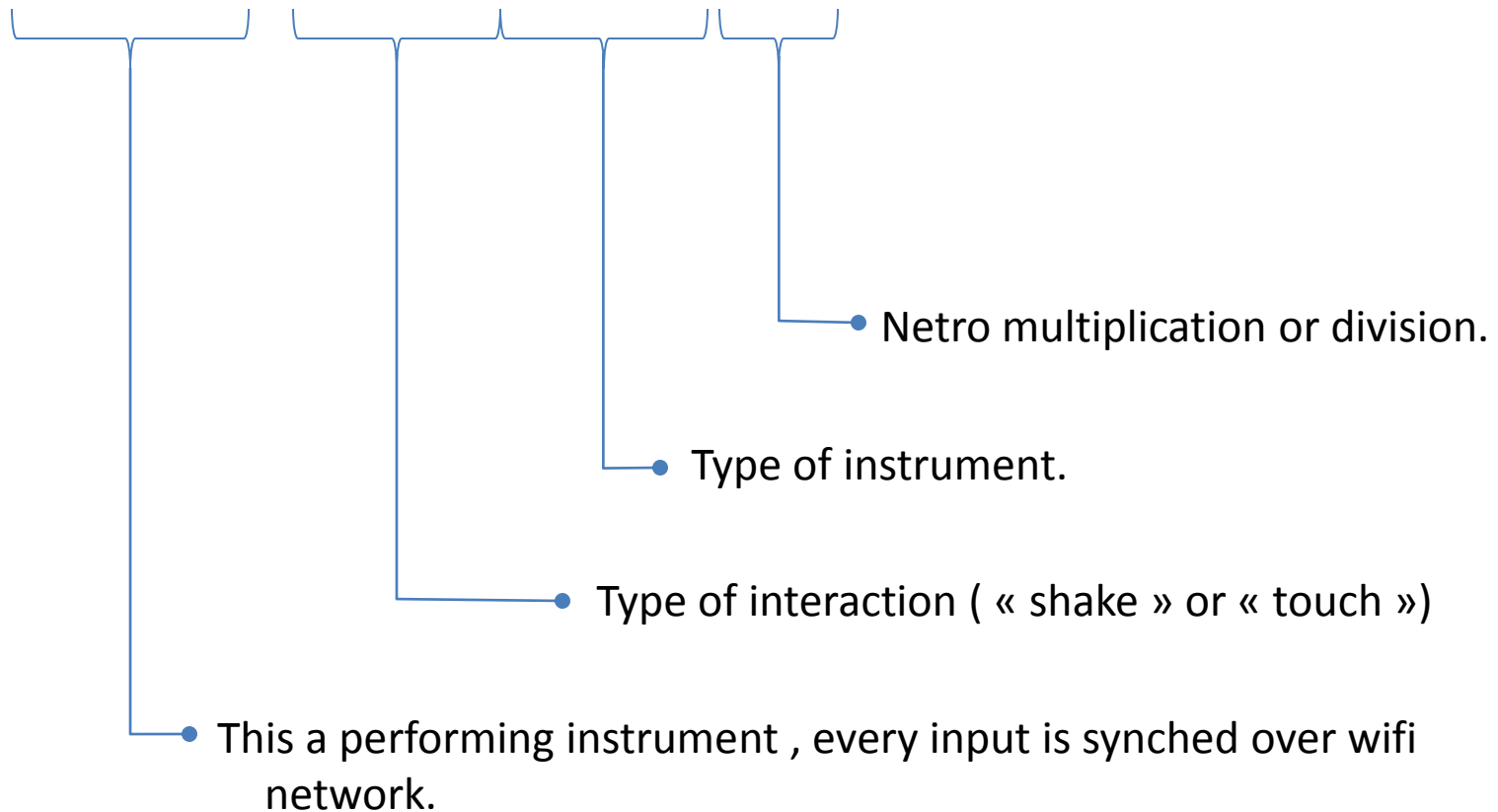

Feedback from users and perspectives

- Necessity for dynamic interface and menus with more feedback on what's happening.
 - ⇒ Standards for UIs are actually quite high from users on smartphones, due to the size of the screen everything needs to be well thought. Separate performance space from customization menus.
 - ⇒ Difficulties to build such interfaces with the tools given in rjdj. (alternatives such as DroidParty, libpd, what about win 8 ?)
- Possibility to have a Sound-On-Sound looper.
 - ⇒ This will be implemented for « netperf » instruments.
- Possibility to record the whole jamming experience.
 - ⇒ Overload of Wlan even for two or three iphones, but each phone can record its own sound, to be re-synchronised in a DAW.

Next

- Electronic music as a social interactive music experience.
- Participative happenings.
- Installation : based on terry riley work, a composition made of 50 iphones that behave as a melodic and rythmic patterns.
- Iphone band : create a band of 4 to 6 members each playing with two iphones.